

Woman's Home Companion

THE CROWELL PUBLISHING COMPANY

250 Park Avenue

New York

THE WOVEN KNITTING BAG

This PDF file was provided by www.eLoomaNation.com for personal use only. Its sale is prohibited and illegal.



Designed by NETTIE
S. HANAUER

H-717

MATERIALS REQUIRED: One, 1-3/4 oz. ball Minerva Spanish worsted in light rust or henna; one 1-3/4 oz. ball in dark rust or henna; small amount of tan for the embroidery; 1/2 yard tan sateen for lining. A Weave-It frame for the 4 inch squares and a "Junior Weave-It" frame for the 2 inch squares. These may be ordered from Milton Bradley Company, 111 - Eighth Avenue, New York City. Price of regular "Weave-it", \$1.00; "Junior Weave-It" 50 cents, plus postage. A wooden frame or handle 12-1/2 inches wide for top of bag.

DIRECTIONS FOR WEAVING AND FINISHING BAG

Make the 12 light and 12 dark 4 inch squares on the larger loom and make the 9 light and 11 dark 2 inch squares on the Junior or smaller loom, following the same directions.

TO WEAVE THE SQUARES: Hold the "Weave-It" frame in front of you, with the red arrow (marked on loom) pointing away from you. Hold the end of the yarn toward you at the arrow, draw the yarn between the pins to the opposite side of the loom, at curved arrow #2, in the direction in which the arrow points. Bring the yarn to the right around the first two pins and return to the side nearest you, drawing the yarn out between the second and third pins at the right of the arrow. Tie the ends of the yarn securely with this yarn you have just brought back to the starting point and be sure it is tied close to the pins. Now, bring the yarn to the right around the next two pins and draw it to the opposite side, bringing it out between the first and second pins in the group directly across. Pass the yarn to the right around the next two pins and back to the near side out between the first and second pins in the next group, around two pins and back etc., until you have reached the curved arrow W, (see sketch 1). Turn loom so the curved arrow W, points directly away from you. Bring the yarn around the first two pins and go to the opposite side, bringing the yarn out between the first and second pins, around two pins and back to the side nearest you, between the first and second pins in the next group etc., until you reach curved arrow #2. (see sketch 2.) Turn loom again so that curved arrow #2 points toward you. Bring the yarn through the first and second pins, down to the side nearest you, coming out between the first and second pins. Bring the yarn around the two pins and go back to the far side, bringing the yarn out of the open space. Go around two pins and back to the side nearest you, coming out of the open space, continue until the loom is filled, (see sketch 3). To ascertain the correct amount of wool needed to weave this square, wind the yarn loosely four and one-half times around the loom on the outside of the pins and break yarn. Unwind the yarn outside of pins and thread the needle. Start at arrow W, between the first and second pins bringing the needle over the outside loop, under the next, over the next, under, over, under etc., (see sketch 4) and draw the yarn completely through. Go around two pins and come back, over the outside loop, under, over, under, over etc., bringing the needle out at the open space. Repeat the last row of weaving next to the pins. Turn corner and tie yarn into the first loop around the pins. When finished remove the square from the loom by pushing up from underneath. The directions for weaving these squares are also enclosed with the "Weave-It" loom.

TO EMBROIDER SQUARES: Use the tan yarn for embroidering all the squares. Over the 12 light, 4" squares work a large daisy 1-1/2" in diameter. (see sketch 5). Baste with white thread a 3/8" circle in center of square, then baste a 1-1/2" circle around it as a guide to make the daisy. Between these bastings, make 8 or 9 petals in lazy-daisy stitch (see sketches 6 and 7). In the center of these petals make a French knot (see sketch 8). Over the 12 dark 4" squares embroider the cross motifs by running bastings in cross effect from corner to corner. Follow these bastings to embroider the design. Also follow sketch of design and work in single over stitches. (see sketch 9). Remove all bastings when finished.

This PDF file was provided by www.eLoomaNation.com for personal use only. Its sale is prohibited and illegal.

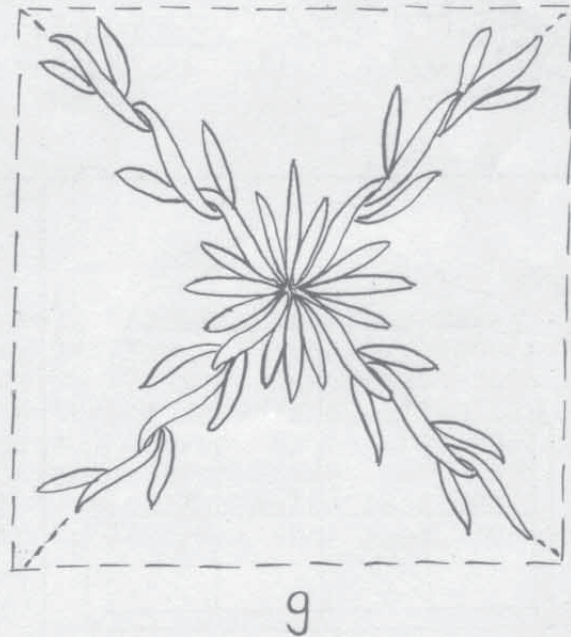
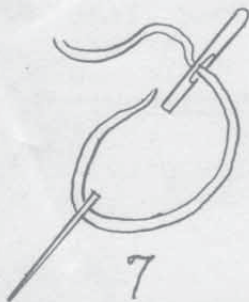
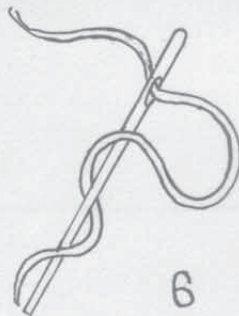
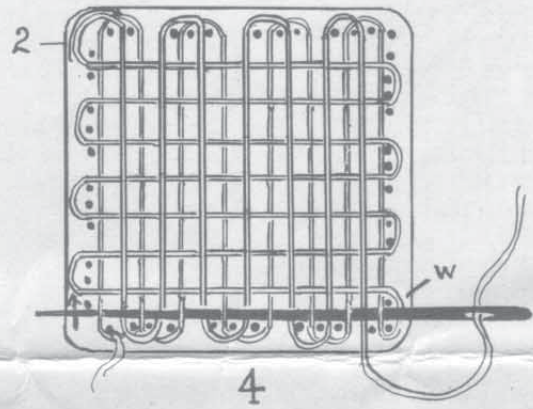
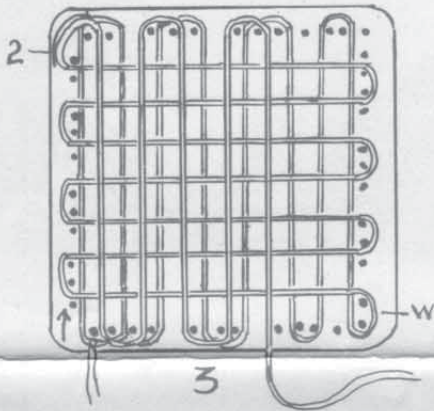
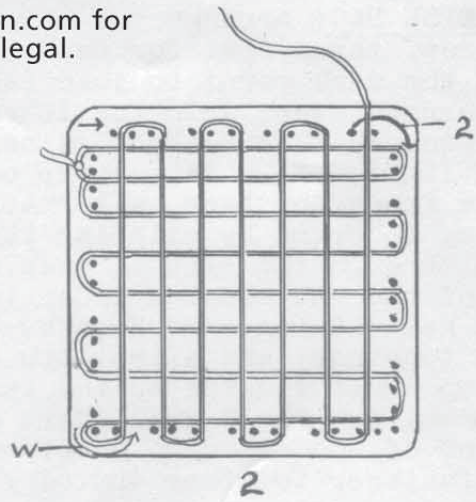
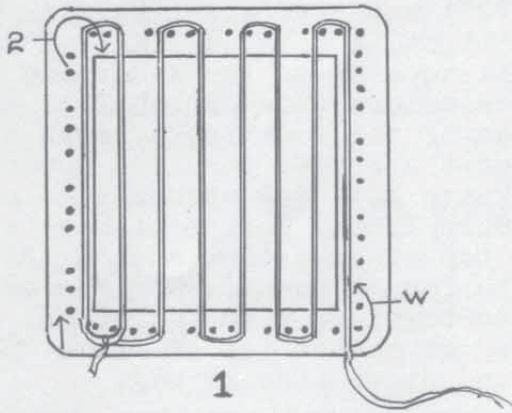

TO FINISH BAG: Arrange the colors of the 4" squares alternately, four in a row, three rows for each side of the bag. Use a faggoting stitch (with the dark yarn) to join (see sketch 10), being careful to keep the corners even. Join the 18 small (2") squares, starting with one dark square, then 2 light, 4 dark, 2 light, 2 dark, 4 light, 1 dark and 1 light. Join this strip of small squares to the sides and bottom of the front and back, alternating the colors (See sketch 11). Attach the bag to frame by slipping the edges of the four top squares of each side, through the slit in each side of the frame. Turn the outer corners of the end squares under (see sketch 12). Sew securely to position. Make lining same size as bag. Slip lining inside of bag (wrong sides together) and slipstitch along top of bag. (See sketch 13). Fold the top small squares to the inside to form a gusset. For the strap fastener, put the 2 small dark squares together with faggoting. Sew one end of the strap to outside of bag at center top of frame. Sew a snap fastener to other end of strap and other side of bag.

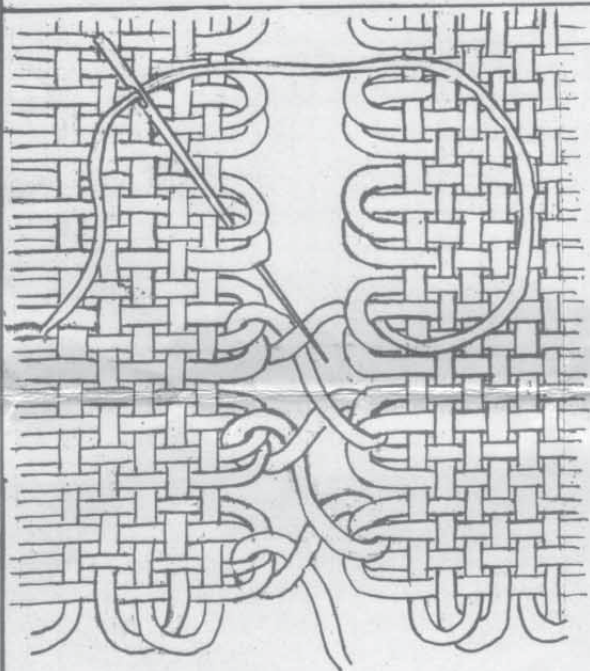

10

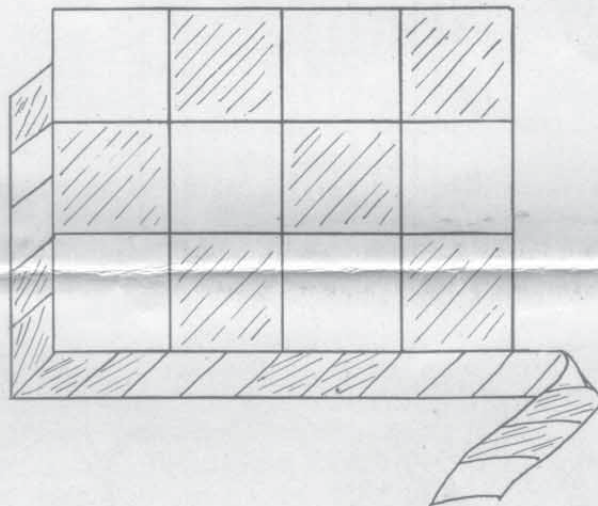

11

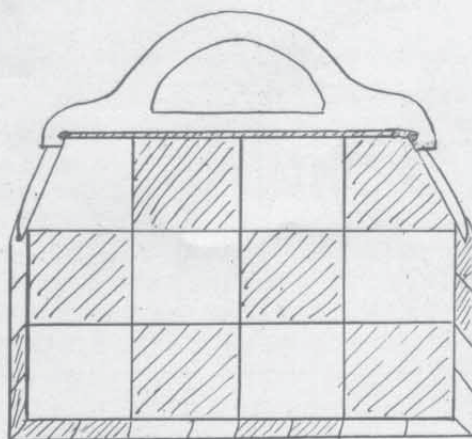

12

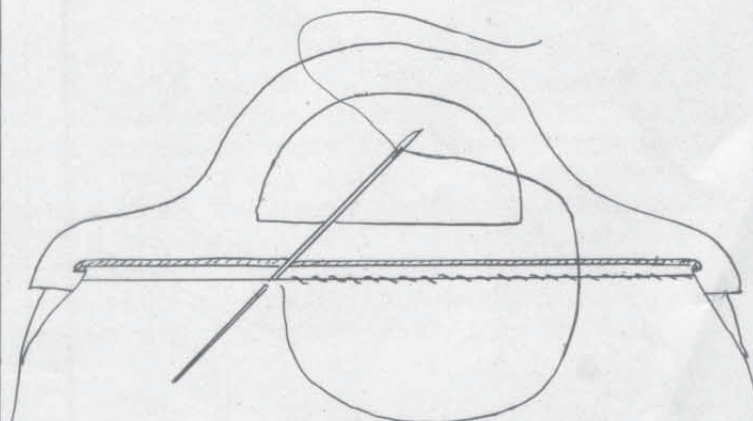

13